

DSP6035

30W Outdoor Waterproof Wall-Mounted Speaker



Description

The product is an outdoor waterproof wall-mounted speaker, which features IP66 waterproof level. It consists of tweeter and woofer units for clear and bright sound. The speaker box is made of polymer engineering plastics and the mesh is made of aluminum material for stable and reliable operation in indoor and outdoor environments.

Features

- Specialized in sound quality, featuring a passive radiator and equipped with both tweeter and woofer units to deliver clear, transparent, and bright sound with rich, powerful bass.
- Streamlined design, smooth and elegant curves, stylish and classy outlook.
- Available in black and white, suitable for the decorative styles of different venues.
- Mesh: Made of 1060 pure aluminum, which is hardened and anti-oxidation treated, not easy to deform and never rust.
- Speaker box: Made of polymer engineering plastics, durable, safe and reliable.
- Speaker unit: The tweeter diaphragm is made of natural silk membrane; the woofer diaphragm is made of polypropylene with large magnetic circuit.
- Mounting bracket: Cast aluminum molding, no oxidation and rust, safe and durable, multi-angle adjustment, easy to install and use.
- Waterproof level: IP66 waterproof level, all-weather design, to ensure the reliable use in indoor and outdoor environments.

Specifications

Model	DSP6035
Speaker Unit	5.25"×1, 1"×1
Operating Voltage	100V
Rated Power	30W
Power Adjustment	8Ω-30W-15W-8W-5W-2.5W
Frequency Response	70Hz-20kHz
Sensitivity (1m, 1W)	86dB±2dB
MAX. SPL. (1m)	101dB±2dB
Dimensions (H×W×D)	275×185×208mm
Net Weight (1PC)	3.8kg
Gross Weight (2PCS/CTN)	10.5kg

Product Information

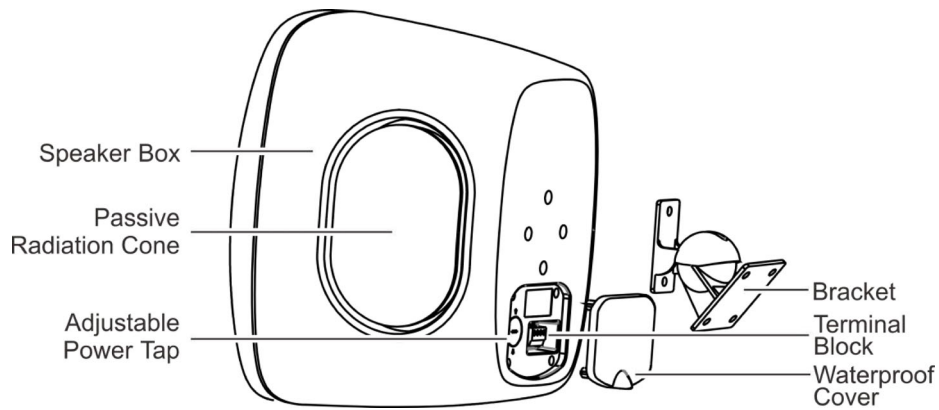

Product Breakdown Structure



H	W	D
275	185	208

Frequency Response
(dB SPL, 1W, 1m)

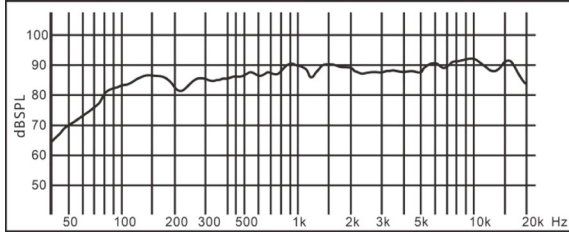

Distortion
(THD < 3% 1W, 1m, 100Hz-10kHz)

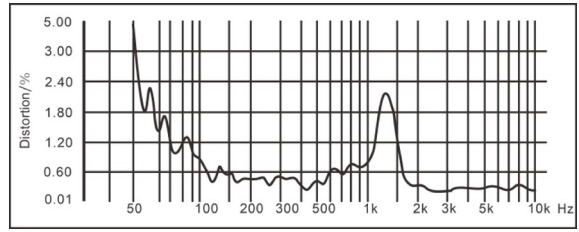

Vertical Directivity Pattern

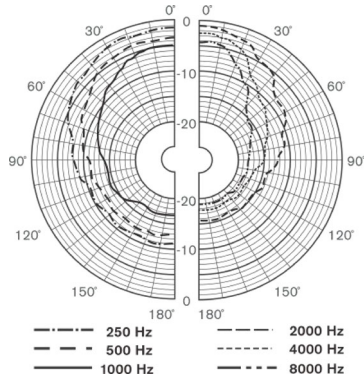

Horizontal Directivity Pattern

